

FAST HIGH VOLTAGE THYRISTOR SWITCH

HTS 350-800-SCR 35 kV / 8 kA

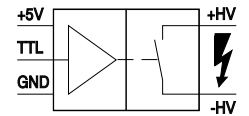

Standard

Option CF

Option CCS



High Surge Current Capability - Extremely High di/dt - Easy Integration

These solid-state switches are designed for high voltage high peak current switching applications such as shock wave generators, flash lamp drivers, crow bar circuits and surge generators. The switching modules contain a large number of reverse blocking thyristors (SCR) for high surge conditions. Several hundred of these SCR's, each with its own low-impedance gate drive, are connected in series and in parallel to ensure the extreme di/dt of upto 16 kA/ μ s. The safe and synchronous control of all SCR's is performed by a special driver circuit which also provides the high galvanic isolation necessary for high-side circuits and safety-relevant applications.

In contrast to conventional high voltage switches like spark gaps, electron tubes, gas discharge tubes and mechanical switches, the thyristor switches of series SCR show very stable switching characteristics independent of temperature and age. The mean time between failures (MTBF) is by several orders of magnitude higher than that of the classical HV switches.

An interference-proof control circuit provides signal conditioning, auxiliary voltage monitoring, frequency limitation and temperature protection. In case of false operating conditions, the switches are immediately inhibited and a fault signal is generated. Three LED's indicate the operating state. The switches are triggered by a positive going pulse of 3-10 Volts. The switching behaviour will not be influenced by the trigger rise time or the trigger amplitude. After being triggered the switches remain in on-state until the load current drops below the holding current (typical thyristor behaviour). The turn-off process requires insofar a current commutation, a current limitation or a current bypass. Capacitor discharge applications with charging currents less than the holding current do not require special turn-off measures. In all other cases, the switches can be turned off by a slight current reversal, which is nevertheless given in most pulsed power applications anyway. If the current reversal is higher than 10%, and if the periodic duration of the current is shorter than 1 ms, a fast kiloamp free-wheeling diode (external diode FDA 350-150 or built-in diode option I-FWD) must be used to avoid hard turn-off.

The plastic case is the cost-effective standard package in low frequency applications with low average power. For higher loads, there are additional cooling options such as ceramic cooling surface, non-isolated cooling fins, grounded cooling flange or liquid cooling, either for conductive and non-conductive liquids. With these options the Maximum Continuous Power Dissipation Pd(max) can be increased up to 30kW. For further design recommendations please refer to the general instructions.

Basic Circuits

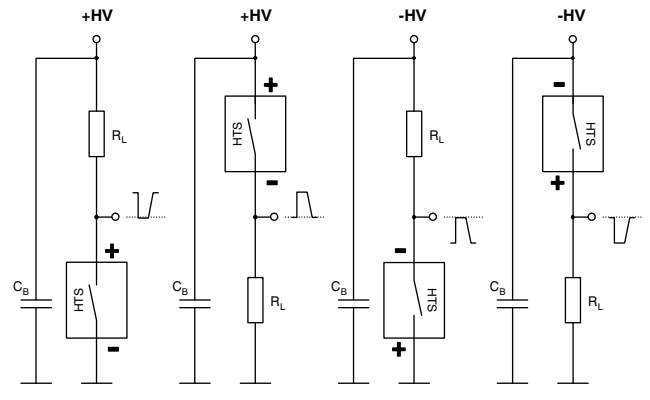

Test Circuit for $t_{r(on)}$

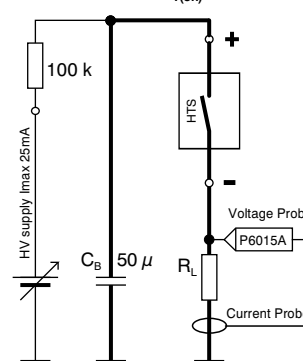

Notes:

1. Total wiring inductance < 50 nH
2. CB is a MAXWELL low inductance energy storage capacitor (<10 nH)
3. RL depends on voltage and peak current test conditions. Low inductance mass resistors, CESIWID series 900, washer style, 3 inch disc diameter, Emax=27600 J/disc.
4. Voltage probe: Tektronix P6015A
Current probe: Pearson 4997
Oscilloscope: Tektronix TDS684C

Control Connection

- Use shielded cables or apply optical decoupling at trigger input
- Input should be terminated properly if connected via coaxial line
- Never mix control wiring and load circuit wiring.

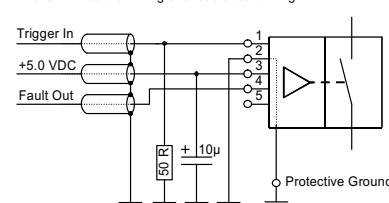

- 1 - Trigger Input (3-10 V)
- 2 - GND (Logic Ground)
- 3 - +5.00 VDC (600 mA DC)
- 4 - Fault Signal Output (TTL)
- 5 - Optional SYNC I/O or GND (Logic Ground)

Inductive Load

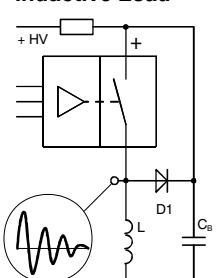

Note: D1 is a fast recovery diode with Kiloamps peak current capability (E.g. Behlke Series FDA)

SPECIFICATION	SYMB.	CONDITION / COMMENT		HTS 350-800-SCR	UNIT
Maximum Operating Voltage	$V_{O(max)}$	$T_{case} = 25\text{ }^{\circ}\text{C}$, $I_{off} < 100\text{ }\mu\text{ADC}$		35000	VDC
Minimum Operating Voltage	$V_{O(min)}$	$t_{r(on)}$ and $t_{r(off)}$ may increase slightly if operated below 5% of $V_{O(max)}$		0	VDC
Typical Breakdown Voltage	V_{Br}	Typical value ($\pm 5\%$), $I_{off} > 1\text{ mADC}$, $T_{case} = 70\text{ }^{\circ}\text{C}$		44000	VDC
Galvanic Isolation Voltage	V_I	Continuously	Standard plastic case Option PT-HV (pig tails for HV connection)	50000 60000	VDC
Maximum Peak Current	$I_{P(max)}$	$T_{case} = 25\text{ }^{\circ}\text{C}$ $T_{fin} = 70\text{ }^{\circ}\text{C}$ Please consult factory for further peak current data / pk. current curves.	$t_p < 100\text{ }\mu\text{s}$, duty cycle $< 1\%$ $t_p < 500\text{ }\mu\text{s}$, duty cycle $< 1\%$ $t_p < 1\text{ ms}$, duty cycle $< 10\%$ $t_p < 10\text{ ms}$, duty cycle $< 10\%$	8000 4000 2720 1600	ADC
Max. Non-repetitive Peak Current	$I_{P(nr)}$	$T_{case} = 25\text{ }^{\circ}\text{C}$ $T_{fin} = 70\text{ }^{\circ}\text{C}$	Half sine single pulse, $t_p < 200\mu\text{s}$ Half sine single pulse, $t_p < 20\mu\text{s}$	16000 32000	ADC
Max. Continuous Load Current	I_L	$T_{case} = 25\text{ }^{\circ}\text{C}$ $T_{fin} = 70\text{ }^{\circ}\text{C}$	Standard plastic case With option CCS (air velocity on surface $> 4\text{ m/s}$) With option CF (air velocity $> 4\text{ m/s}$, true laminar flow)	2.2 4.4 18.5	ADC
Typical Holding Current	I_H	$T_{case} / T_{fin} = 25\text{ }^{\circ}\text{C}$ $T_{case} / T_{fin} = 70\text{ }^{\circ}\text{C}$		50 35	mADC
Typical On-State Voltage	V_{sat}	$T_{case} / T_{fin} = 25\text{ }^{\circ}\text{C}$ $t_p < 10\text{ }\mu\text{s}$, duty cycle $< 1\%$	$0.001 \times I_{P(max)}$ $0.01 \times I_{P(max)}$ $0.1 \times I_{P(max)}$ $1.0 \times I_{P(max)}$	34 40 66 176	VDC
Typical Turn-On Delay Time	$t_{d(on)}$	Typical value ($\pm 5\%$), rising edges 50-50%, $0.8 \times V_{O_{max}}$ @ $I_{P(max)}$		430	ns
Typical Turn-On Rise Time (Output Pulse Rise Time)	$t_{r(on)}$	Resistive load, 10-80%	$0.1 \times V_{O(max)}$, $0.1 \times I_{P(max)}$ $0.8 \times V_{O(max)}$, $0.1 \times I_{P(max)}$ $0.8 \times V_{O(max)}$, $1.0 \times I_{P(max)}$	550 180 450	ns
Typical Turn-Off Time	t_{off} , t_q	$T_{case} / T_{fin} = 25\text{ }^{\circ}\text{C}$ inductive load / free wheeling diode	$0.01 \times I_{P(max)}$ $0.1 \times I_{P(max)}$ $1.0 \times I_{P(max)}$	10 35 90	μs
Critical Rate-of-Rise of Off-State Voltage	dv/dt	@ $V_{O(max)}$, exponential waveform		200	$\text{kV}/\mu\text{s}$
Maximum On-Time	$t_{on(max)}$	Depends on holding current only. Please consult factory for further data.		unlimited	
Internal Driver Recovery Time	t_{rc}	Standard devices With option HFB		1000 100	μs
Typical Turn-On Jitter	$t_{j(on)}$	$V_{aux} / V_{tr} = 5.00\text{ VDC}$		1	ns
Max. Cont. Switching Frequency	$f_{(max)}$	Please note $P_{d(max)}$ limitations, increased $f_{(max)}$ on request		350	Hz
Maximum Burst Frequency	$f_{b(max)}$	With option HFB, $I_{P(max)} < 4\text{ kA}$ With option HFB, $I_{P(max)} < 800\text{ A}$		1 10	kHz
Maximum Continuous Power Dissipation	$P_{d(max)}$	$T_{case} = 25\text{ }^{\circ}\text{C}$ $T_{fin(max)} = 70\text{ }^{\circ}\text{C}$	Standard plastic case With option CCS (air velocity on surface $> 4\text{ m/s}$) With option CF (air velocity $> 4\text{ m/s}$, true laminar flow)	75 150 650	Watts
Linear Derating		Above $25\text{ }^{\circ}\text{C}$	Standard plastic case With option CCS (air velocity on surface $> 4\text{ m/s}$) With option CF (air velocity $> 4\text{ m/s}$, true laminar flow)	1.666 3.333 14.444	W/K
Operating Temperature Range	T_O	Extended temperature range on request		-40...70	$^{\circ}\text{C}$
Storage Temperature Range	T_{ST}			-50...90	$^{\circ}\text{C}$
Coupling Capacitance	C_c	Stray capacitance between HV side and grounded control side		310	pF
Aux. Supply Voltage Range	V_{aux}	V_{aux} has no impact on the dynamic switching behavior.		4.75 to 5.25	VDC
Auxiliary Supply Current	I_{aux}	Typical value ($\pm 10\%$), @ $V_{aux} = 5.0\text{ V}$, $T_{case} = 25\text{ }^{\circ}\text{C}$.	@ $f < 30\text{ Hz}$ @ $f = 300\text{ Hz}$	390 520	mADC
Trigger Signal Voltage Range	V_{tr}	3 to 5 V recommended for low jitter. $V_{tr} > 5.5\text{ V}$ will be clamped.		2-10	VDC
Minimum Trigger Pulse Width	$t_{ptr(min)}$	The trigger pulse has no impact on the dynamic switching behavior.		50	ns
Max. Trigger Pulse Rise Time	$t_{tr(min)}$	Trigger slope is uncritical due to "Schmitt Trigger" input characteristics.		∞	ns
Trigger Input Impedance	Z_{tr}	Note: TTL trigger input is equipped with protection and filter network.		3.3	$\text{k}\Omega$
Fault Signal Output Voltage		"L" indicates switch over temperature ($> 75\text{ }^{\circ}\text{C}$ / $167\text{ }^{\circ}\text{F}$), driver overload, over frequency and low aux. supply.	"H" signal "L" signal	4 0.5	VDC
Fault Signal Output Current		Source and sink current, output short circuit proof.		10	mADC
Fault Detector Response Time		Switch cannot be damaged by false control conditions.		< 100	ns
LED Indicator Function		Green LED, illuminated continuously in normal operation Yellow LED, illuminated for 20ms if a valid trigger is applied Red LED, illuminated for $\geq 2\text{ sec}$ in a case of fault condition		"Ready / auxiliary power good" "Switch successfully triggered" "Fault / switch is locked for $\geq 2\text{ sec}$ "	
Dimensions	$L \times W \times H$	Standard plastic case Option CF, non-isolated cooling fins, standard flange housing Option CCS, ceramic cooling surface		372 x 200 x 43 372 x 200 x 78 372 x 200 x 46	mm^3
Weight		Standard plastic case Option CCS, ceramic cooling surface Option CF, non-isolated cooling fins		2700 5220 6000	g

Ordering Information (The options listed below are product-typical standard modifications. For further possible options please refer to the "Product Survey A")

HTS 350-800-SCR	Thyristor switch, 35 kVDC, 8kA (pk)	Option CCS	Cooling by ceramic cooling surface. Surface non-conductive. Forced convection. Up to 150 W.
Option I-FWD	Integrated free-wheeling diode	Option CF	Cooling by non-isolated cooling fins. Forced convection. Up to 650 W (up to 1500 W in connection with larger fins).
Option PT-HV	Pigtails for HV connection instead of bus bar terminals	Option GCF 1)	Cooling by grounded cooling flange for classical heatsinks. Please note increased coupling capacitance. Up to 3kW.
Option LP	Low pass filter at trigger input (former option "DT"). Increased delay.	Option ILC 1)	Cooling by indirect liquid cooling. All kind of conductive coolants & water. Increased coupling capacitance. Up to 3 kW.
Option I-PC	Integrated passive part components (e.g. damping resistor 100 Ohm)	Option DLC 1)	Cooling by direct liquid cooling. For non-conductive liquids such as GALDEN HT-135 or silicone oil AK 20. Up to 30 kW.
Option UL-94	Casting resin and housing flame retardant according to UL94-V0		1) Please consult BEHLKE for further information regarding Dimension and Max. Power Dissipation